

QSFP28 ER4

100 Gbps Rate Transceiver

Description:

OPTOKON **100G QSFP28 ER4** optical transceivers are designed for high speed communication applications that requiring rates of from 103.125 Gbps. The transmitter converts 4 inputs channel of 25.78 Gbps electrical data to 4 optical signals with center wavelength of 1296 nm, 1300 nm, 1305 nm and 1309 nm, and multiplexes them into a single channel through an industry standard LC connector. In the receive side, the four lanes of optical data streams are optically de-multiplexed by the integrated optical de-multiplexer. Each data stream is recovered by a PIN photo-detector and trans-impedance amplifier, retimed.

This module features a hot-pluggable electrical interface, low power consumption and MDIO management interface. The product is designed with form factor, optical/electrical connection and digital diagnostic interface according to the QSFP28 Multi-Source Agreement (MSA) and compliant to IEEE 802.3ba and IEEE 802.3bm.



Features:

- Compliant with 100GBASE-ER4
- Support line rates 103.125 Gbps
- Integrated LAN WDM DML(EML) TOSA / APD ROSA, support 30 km without FEC or 40km with FEC
- Digital Diagnostics Monitoring Interface
- Duplex LC optical receptacle
- No external reference clock
- Electrically hot-pluggable
- Compliant with QSFP28 MSA and 4WDM20_40 MSA with LC connector
- Case operating temperature range: 0°C to 70°C
- Power dissipation < 4.5 W

Safety and regulatory compliance and standards: Applications:

- Compliant to IEEE 802.3ba, IEEE 802.3bm
- Compliant with QSFP28 MSA and 4WDM20_40 MSA with LC connector
- Compliant to SFF-8636
- 100G Ethernet & 100GBASE-ER4

Recommended operating conditions:

<i>Parameter</i>	<i>Min</i>	<i>Typ</i>	<i>Max</i>	<i>Unit</i>	<i>Note</i>
Case Operating Temperature	0	-	70	°C	Without air flow
Relative Humidity	5	-	95	%	
Power Supply Voltage	3.13	3.3	3.47	V	
Data Rate		25.78125		Gbps	Each channel
Transmission Distance		30	40	km	
Coupled fiber	Single mode fiber				9/125um SMF

Optical characteristics:

Transmitter

Parameter	Min	Typ	Max	Unit
Signaling Speed per Lane		25.78125		Gbps
Wavelength Assignment	1294.53	1295.56	1296.59	nm
	1299.02	1300.05	1301.09	nm
	1303.54	1304.58	1305.63	nm
	1308.09	1309.14	1310.19	nm
Total Output Power			10.5	dBm
Average Launch Power per Lane	-2.5		6.5	dBm
Average launch Power OFF per Lane			-30	dBm

Receiver

Parameter	Min	Typ	Max	Unit
Receive Power per Lane (Max)			-3.5	dBm
Receiver Sensitivity (OMA), each Lane (BER = 5x10 ⁻⁵)			-18.5	dBm
Receiver Sensitivity (OMA), each Lane (BER = 1x10 ⁻¹²)			-14	dBm
LOS De-Assert			-18	dBm
LOS Assert	-35		-14	dBm

Dimension:

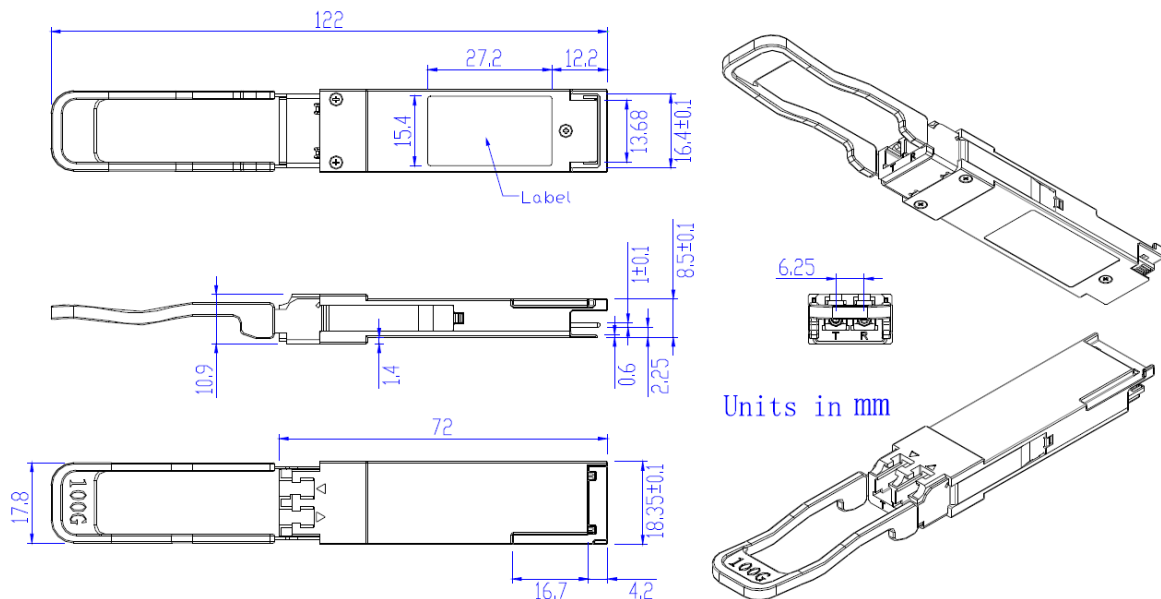

Ordering code

Code	Description
S100G-QP28-ER4-30-D-XX	100 Gbps (4x25 Gbps), QSFP28 housing, 30 km without FEC, 0°C to +70°C, LC connector
S100G-QP28-ER4-40-D-XX	100 Gbps (4x25 Gbps), QSFP28 housing, 40 km with FEC, 0°C to +70°C, LC connector